

Typical Installation in small garage

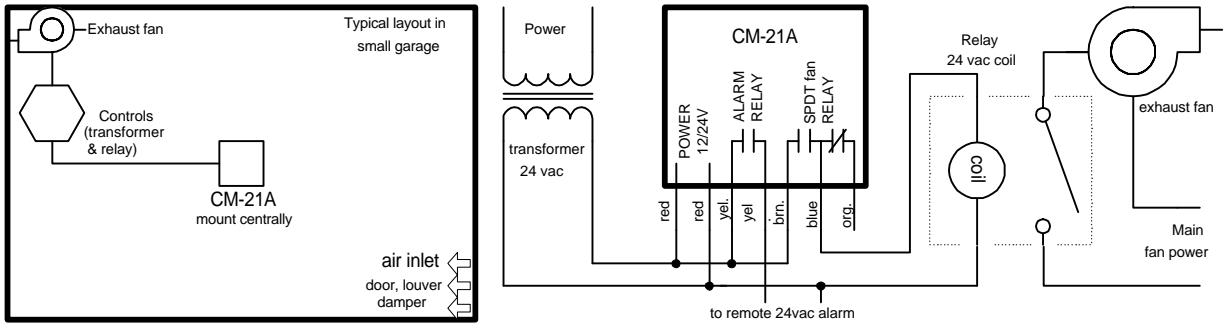

Typical multiple CM-21A installation

INSTALLATION NOTES

1. One sensor per 5000 square feet (approximately).
2. Mount CM-21A four to five feet above the floor.
3. See applicable building code for fan size vs air changes per periods of time.
4. Make sure there are air inlets to provide adequate air flow throughout the building.
5. CM-21A fan relays are dry contact & can switch up to 240V: see ratings, over.
6. Several fan relays (starters) may be used. Match the relays to the fan size.

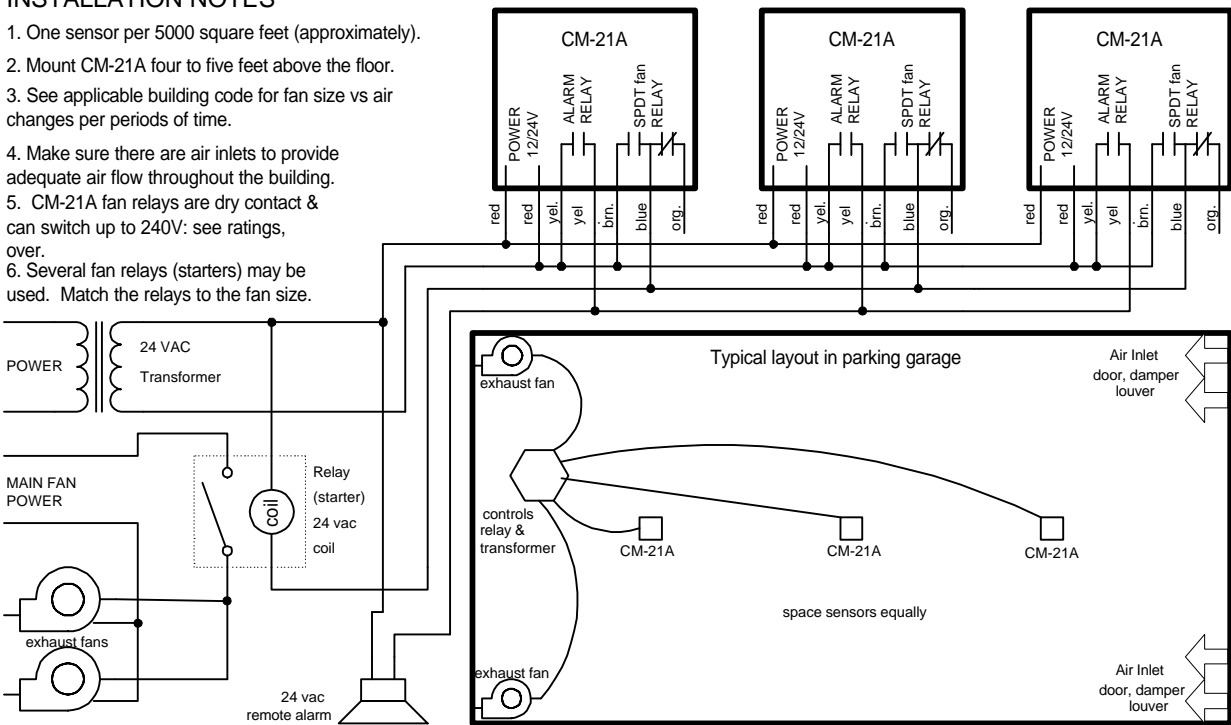

Typical Connection to Alarm Control Panel

1. CM-21A can be used with 12vdc or 24vdc N.O. (fire) panels.
2. Alarm panel provides battery backed up power to CM-21A.
3. CM-21A dry contact fan relay can use panel power or fan power: check ratings.
4. Match fan relay contacts to fan size, and coil voltage to power source.
5. Alarm Control Panels are available with many features & can control other devices such as smoke detectors, fire detectors & burglar alarms.

